

DIESEL GENERATOR SET

MTU 8V1600 DS400

400 – 230 V/350 kVA/50 Hz/Prime Power
Series 1600 – MTU 8V1600



Optional equipment and finishing shown. Standard may vary.

PRODUCT HIGHLIGHTS

// Benefits

- Industry-leading average load factor
- Low fuel consumption
- Emissions optimizations available
- High availability and reliability
- Outstanding load acceptance
- Long maintenance intervals

// Support

- Global product support offered

// Standards

- Engine-generator set is designed and manufactured in facilities certified to standards ISO 2008:9001
- Generator set complies to ISO 8528 and fulfills performance level G3
- Generator meets BS5000; NEMA MG 1; ISO; DIN EN and IEC standards
- NFPA 110

// Available optimizations

- TA-Luft (NO_x < 1500mg/m³ i.N.) optimized
- Exhaust emission EU 97/68 EC Stage III A
- NEA Singapore for off road diesel engines (ORDE)
- ARAI CPCB Stage II
- Fuel optimized

// Wide Standard Scope of Supply

- 4P circuit breaker
- Island operation control panel
- Integrated fuel tank
- Industrial silencer (15 dB(A))
- Batteries & battery charger

// Complete range of accessories available

- Sound attenuated enclosure
- Fuel system accessories
- Control panel & ATS
- Range of additional electrical options

// Warranty

- Standard 36 months warranty after shipment

APPLICATION DATA^①

// Engine

Manufacturer	MTU
Model	8V1600G10F
Type	4-cycle
Arrangement	8-V
Displacement: L	14
Bore: mm	122
Stroke: mm	150
Compression ratio	17.5
Rated rpm	1500
Engine governor	ECU 8
Gross power: kWm	325
Air cleaner	Dry

// Fuel System

Max. fuel flow: L/h	342
Fuel tank capacity: OPU (EPU) in L	740 (740)
Autonomy: h	12

// Fuel Consumption

	L/h
At 100% of power rating:	79.36
At 75% of power rating:	61.5
At 50% of power rating:	44.22

// Liquid Capacity

Total oil system: L	46
Total coolant capacity: L	84

// Generator

Generator brand	Mecc-Alte
Generator type	HM355A1
Insulation class	H-class
Bearing	single bearing
Enclosure	IP23 M
Voltage regulation	A.V.R. (electronic)
Exciting system	self-excited, brushless

// Electrical

Electric system volts DC	24
Number of batteries	2
Capacity: Ah	2x 75

// Air Requirements

Aspirating: m ³ /min	22.8
Cooling air flow: m ³ /s	6.5

// Exhaust System

Gas temp. (stack): °C	490
Gas volume at stack temp.: m ³ /min	55.8
Maximum allowable back pressure: kPa	15

// Cooling/Radiator System

Ambient capacity of radiator in OPU (EPU): °C	50 (50)
Pressure on rad. exhaust: kPa	0.2
Heat rejection to coolant: kW	170

① Technical data is for a fuel-optimized unit.

STANDARD AND OPTIONAL FEATURES

// System Ratings (kW/kVA)

	MTU 8V1600 DS400
	Prime operation
Voltage	400 V
Phase	Three phase
Hz	50
kWel*	280.0
kVA**	350
Rated AMPS	505.2

* cos phi = 1,0

** cos phi = 0,8

Also available for following voltages 380V & 415V - for details please contact your local MTU Onsite Energy Dealer.

// Engine

- 4- strokes diesel engine
- Flywheel housing SAE 1
- Flywheel 14"
- Four-valve, overhead camshaft
- Piston cooling via oil spray nozzle
- Forged crankshaft & connecting rods
- Oil pan
- Lube oil circulation pump
- Dry exhaust manifolds
- Hot components and radiator guards
- Mobile components guards
- Lube oil filter

// Fuel system

- Fuel main filter
- Fuel pre-filter with water separator
- Common rail fuel injection
- Integrated fuel tank (level sensor and drain cap incl.)
- Automatic fuel transfer pump
- Heavy-duty fuel pre-filter with water separator
- 3-way valve for fuel filling
- Fuel cooler

// Generator

- 3-Phase, synchronos, brushless, self exciting, self regulating, self ventilating alternator
- Winding temperature sensors
- IP23 M protection degree
- IP23 protection cover
- Bearing temperature sensors
- Insulation class H
- Anti condensation heater
- Permanent magnet

// Control Panel & Electric Options

- Control and power electric panel, with measurements devices and controller
- ATS (Automatic Transfer Switch)
- Control version for parallel operation
- Control version for synchronizing a single genset with mains
- Programmable timer for MM7 and MC7
- Remote display
- Expansion module for CAN communication
- Change over power supply for MC7
- Input Output/LED expansion modules for DeepSea controllers
- ModBus connection to customer systems TCP/IP
- Control version for synchronizing with mains without blackout
- Converter kits CAN to RS485/USB/LAN

Represents standard features

Represents optional features

STANDARD AND OPTIONAL FEATURES, CONTINUATION

// Circuit Breaker/Power Distribution

- 4 poles manual circuit breaker (motorized with DeepSea controllers)

// Starting/Charging System

- | | | |
|--------------------------------|--|-------------------------------|
| ■ 24V electric system | ■ Pre-heating resistance/jacket water heater | ■ Battery charging alternator |
| ■ Starting batteries installed | | ■ Battery disconnecter |
| | | ■ Battery charger |

// Air Intake System

- | | |
|--|---|
| ■ Exhaust turbochargers | ■ Intercooler, integrated in radiator |
| ■ Set of dry-type air filters with containment indicator | <input type="checkbox"/> Heavy duty air filter with automatic dust evacuation |

// Exhaust System

- | | | |
|--------------------------------|--|--|
| ■ Industrial silencer 15 dB(A) | <input type="checkbox"/> Residential silencer 35 dB(A) | <input type="checkbox"/> Exhaust bellows |
|--------------------------------|--|--|

// Cooling System

- | | | |
|----------------------------|---|----------------------------|
| ■ Coolant circulation pump | ■ Front type radiator for jacket water and charge aircooling circuit with integrated expansion tank | ■ Engine mounted fan drive |
|----------------------------|---|----------------------------|

// Mounting System

- | | |
|-------------------------------|--|
| ■ Mounted on steel base frame | ■ Resilient mounting of engine and generator |
|-------------------------------|--|

// Enclosures

- | | | |
|--|-------------------------------------|---|
| <input type="checkbox"/> Sound proof enclosure | <input type="checkbox"/> Socket box | <input type="checkbox"/> Increased fuel tank capacity |
|--|-------------------------------------|---|

// Documentation & Certifications

- | | |
|------------------------------|--|
| ■ Genset & component manuals | <input type="checkbox"/> CE-certification for EU |
| ■ Maintenance schedule | ■ Fluids and lubricants specification |

WEIGHTS AND DIMENSIONS

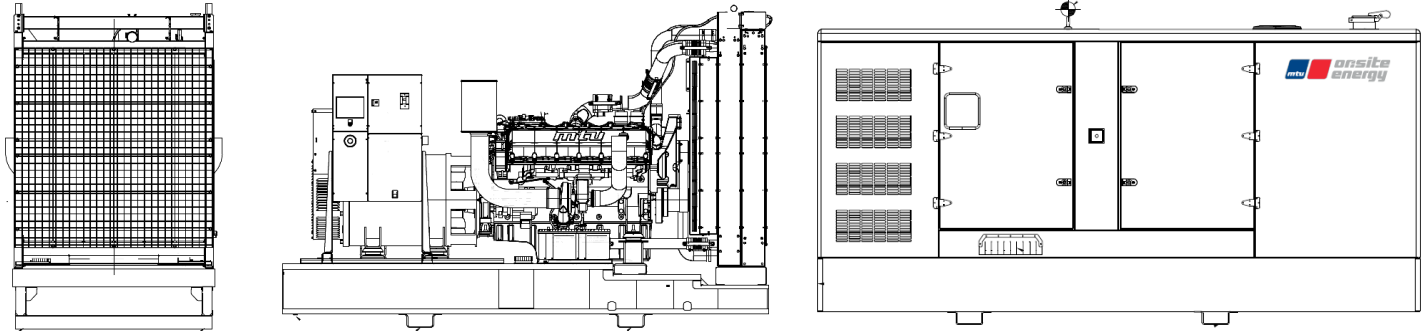

Drawing above for illustration purposes only, based on standard open and enclosed power 400 Volt engine-generator set. Lengths may vary with other voltages. Do not use for installation design. See website for unit specific template drawings.

System	Dimensions (LxWxH)	Weight (wet/with standard accessories)
Open Power Unit (OPU)	3.600 x 1.602 x 2.121 mm	3.496 kg
Enclosed Power Unit	4.500 x 1.800 x 2.340 mm	5.232 kg

Consult the factory for accurate weights and dimensions for your specific engine-generator set. Lengths may vary with other voltages. Do not use for installation design.

SOUND DATA

Unit Type	
Open Power Unit: dB(A)	on request
Enclosed Power Unit: dB(A)	62.8

Sound data is provided at 7m for 75% prime power.

RATING DEFINITIONS AND CONDITIONS

- // Prime power ratings apply to installations where utility power is unavailable or unreliable. At varying load, the number of generator set operating hours is unlimited. A 10% overload capacity is available for one hour in twelve. Ratings are in accordance with ISO 8528-1, ISO 3046-1, BS 5514, AS 2789 and DIN 6271. Average load factor: < 75%.
- // Derating factor:
 - Altitude: Consult your local MTU Onsite Energy Power Generation distributor for altitude deratings.
 - Temperature: Consult your local MTU Onsite Energy Power Generation distributor for temperature deratings.

Rated power for reference conditions at 25°C and 100m above sea level.

Materials and specifications subject to change without notice.